



MAINAIR BLADE 912 AIRCRAFT MANUAL

Ref: BD912 Manual
Date: 1st October 2002
Issue: 3

Aircraft Details

Registration.....

Serial Number.....

Date.....

Batten Issue.....

Customer.....

Dealer.....

Engine Number.....

Contents

- 1.0 Introduction
- 2.0 General Description
- 3.0 Warning About the Safe Operation of Your Blade
- 4.0 Specifications
 - 4.1 General Data
 - 4.2 Weights and Loading
 - 4.3 Performance
 - 4.4 Engine and Propeller Limitations
- 5.0 Normal Procedures
 - 5.1 Transportation
 - 5.2 Rigging
 - 5.3 De-rigging
 - 5.4 Rigging and Derigging Inspection
- 6.0 Pre-Flight Checks
- 7.0 Flight Characteristics and Operating Procedures
 - 7.1 Operating Areas
 - 7.2 Load Distribution and C.G.
 - 7.3 Single Seat Operation
 - 7.4 Fuel Tanks and Fuel Priming
 - 7.5 Flight Limitation Placards
 - 7.6 Flight Control
 - 7.7 Ground Handling
 - 7.8 General Flying
 - 7.9 Take Off
 - 7.10 Landing
 - 7.11 Engine Off Procedure
 - 7.12 General Flight Control
 - 7.13 Stalls
 - 7.14 Turning Stalls
 - 7.15 Whipstalls
 - 7.16 Flight in Rain and Ice
 - 7.17 Minimum Cockpit Load and Operation and Light Weight
 - 7.18 Wing In Flight Trimmer
 - 7.19 Wing Tuning and Adjustment
 - 7.20 Wing Trim
 - 7.21 Adjustments in Pitch
 - 7.22 Adjustments in Roll
 - 7.23 Wheel Spats
- 8.0 Starting Up
 - 8.1 Starting Up
- 9.0 Care & Maintenance
 - 9.1 Airframe Life and Maintenance Schedule
 - 9.2 Fabric

- 9.3 Stitching Damage
- 9.4 Cleaning
- 9.5 Ultraviolet Degradation
- 9.6 Rigging Wires
- 9.7 Battens
- 9.8 Tubes
- 9.9 Bolts and Nuts
- 9.10 Fittings
- 9.11 Care and Cleaning
- 9.12 Salt Water or Beach Conditions
- 9.13 Grass Field operation
- 9.14 Wheels
- 9.15 Control Cables
- 9.16 Exhaust System
- 9.17 Engine Mountings
- 9.18 Fuel Tanks, Fuel Lines and Filters
- 9.19 Electrical System
- 9.20 Propeller Care
- 9.21 Propeller Pitch Settings

- 10.0 Propeller Assembly Instructions

- 11.0 Record of Running Hours

- 12.0 Modification and Part Failure Log

- 13.0 Maintenance Record

- 14.0 Wiring Diagram

Appendix A Mod 99 – 65 Litre Fuel Tank

1.0 Introduction

Thank you for purchasing a Mainair Blade 912. This aircraft is a state of the art flex-wing offering high performance combined with ease of handling and operation.

Prior to your collection the aircraft has had a detailed factory inspection, and will be subject to a further inspection by your Mainair dealer, he is also responsible for ensuring that you are fully familiar with your new Blade 912, in particular rigging and de-rigging and general flying. If you are unsure of any of these aspects please contact your dealer, or Mainair Sports.

This manual has been written to help you operate and maintain your Blade 912 in the same condition that you have received it, please familiarize yourself with its contents before you operate your aircraft.

If there are any queries please do not hesitate to contact your Mainair dealer or Mainair Sports.

2.0 General Description

The Mainair Blade 912 is a high performance, two seat, flex wing microlight controlled by weight shift.

The trike unit features, full all round suspension, twin rear brakes, trailing link front suspension, single fuel tank, purpose built hand throttle, Rotax 912 engine and distinctive Mainair styling. All aluminium tubing is anodized, seamless 6082 Alloy, and all components are multi-sleeved and bushed as appropriate to reduce wear and ensure a long life. All steel components are MIG welded and plated for durability.

The wing features an 85% double surface, with floating cross tube, and multi sleeved anodized 6082 aluminium spars throughout. Roll swages or Nicopress swages are used on all cables for durability and reliability. Heavy duty white sailcloth is used on the top surface, and coloured cloth for the lower surface. The trailing edge is reinforced with a full span polyester cord to retain the stretch characteristics of the wing, but ensure strength. An in flight trimmer is provided to enable cruise at different speeds.

All bolts used for the mainframe are aircraft quality AN bolts.

All aircraft are built to and comply with the exacting standards of BCAR Section S.

DWG NO. 99-44-BL912GA

TITLE Mainair Blade 912 & 912S General Assy

DATE 16th March 2000

SUPERCEDES

DRAWN BY *[Signature]* CHECKED BY *[Signature]*

REF DATE AMENDMENT

1 16/03/00 New Drawing, Includes Blade 912S

See: 99-44-65 For Trike Details
B-001 For Wing Details

MAINAIR SPORTS LTD.
TEL: 01706 655134

TOLERANCES UNLESS STATED OTHERWISE
GENERAL ± 1.0MM DIMETERS ± 0.05MM

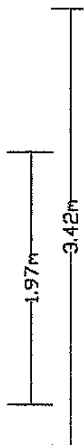
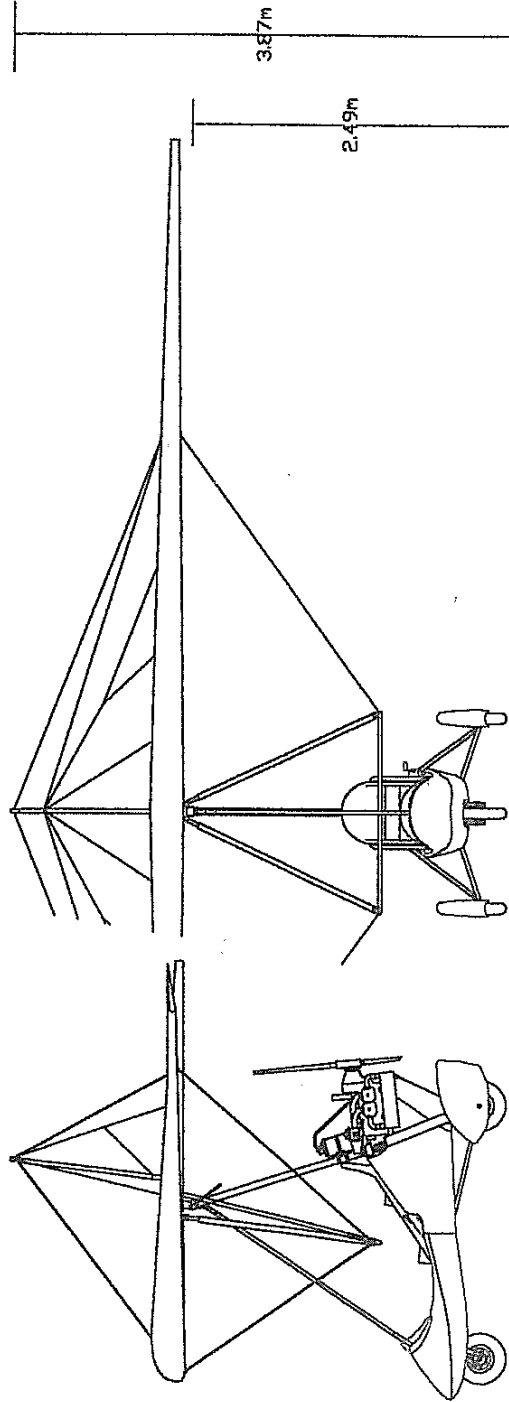
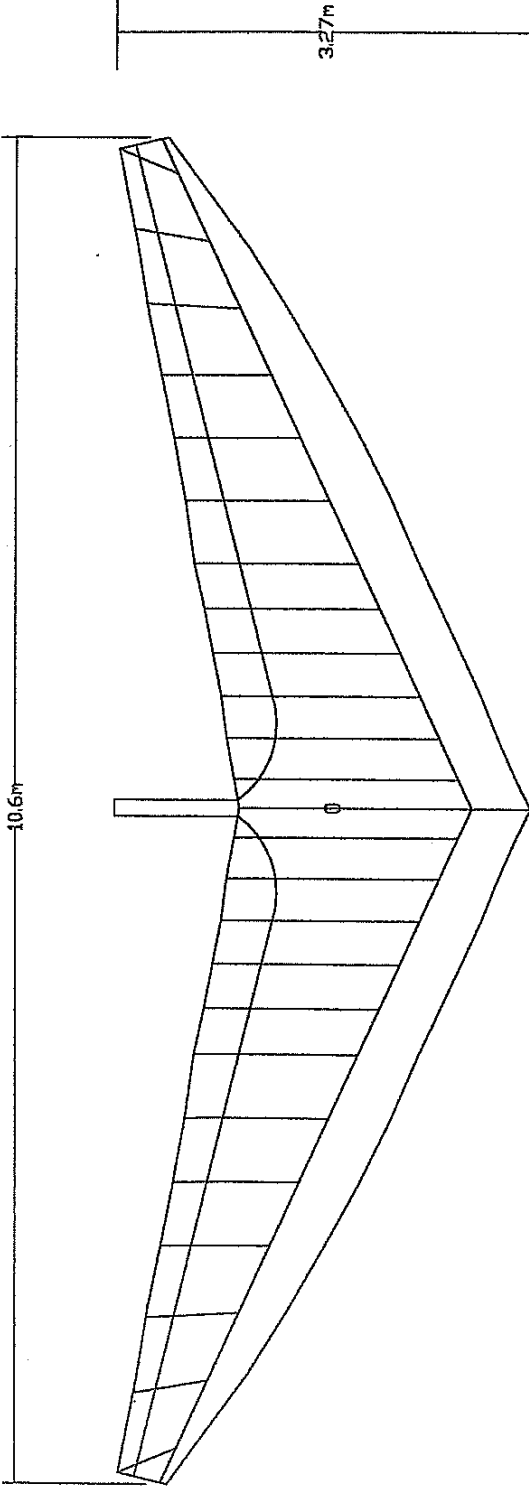

DO NOT SCALE

3.0 Warning About The Safe Operation Of Your Blade 912

The Blade 912 is certified for non-aerobatic flight only. This means any manoeuvre necessary for safe operation, stalls, steep turns upto a maximum bank angle of 60 deg, and maximum pitch up and pitch down of the wing from normal flight of 30 deg. Spins, whip stalls, tail slides and wing overs are all prohibited.

Loss of flight control may result from negative loading which can occur from steep pitch and/or roll manoeuvres in excess of the above values. It is dangerous to conduct steeply banked reverse turns, wing overs and whip stalls and to fly the aircraft at speeds beyond Vne. Positive action must be taken to avoid your own and other aircraft's wake turbulence.

Be aware of the flight limitations at all times and operate this aircraft in a sensible and considered manner.

Positive loading must be maintained at all times.

Always fly in such a manner that engine failure, or component failure, for what ever cause, does not preclude a safe emergency landing. You should always fly with an eye open for a safe landing field. Always operate from a site where failure after take off is not hazardous. Operation of the aircraft acknowledges that you are aware of the dangers of engine or component failure and accept all risks.

Microlighting is, in general, a fair weather sport but light rain has little effect on flying control. You will notice a slight increase in stall speed but the effects are minimal.

Ice, however, is more serious and can occur through icing meteorological conditions, or by flying a wing which is wet from the bag, without giving it time to dry out. Icing will affect handling and speeds markedly and at the first sign you should cease flying or fly below icing conditions.

In addition if the wing has been left out all night, and a frost has formed never fly until the wing is completely dry and all the frost on the wing has gone.

NEVER FLY IF THERE IS ANY ICE OR FROST PRESENT ON THE WING

Spares parts should only be fitted as supplied by Mainair Sports, if any other components or modifications are carried out to the aircraft without prior permission from the factory all guarantees are invalid, and no responsibility can be taken for the continued safe operation of the aircraft. No repairs, other than those detailed in this manual, should be carried out without the prior approval of Mainair Sports.

4.0 Specifications

4.1 General Data

Overall Length	3.36 m
Overall Height	3.83 m
Wing Span	10.6 m
Projected Area	15.6 sqm
Nose Angle	130 deg
Aspect Ratio	7.20
Double Surface	85%

4.2 Weights and Loadings

Empty Weight	190 kg
Maximum Cockpit Weight	172 kg (Pilot+Passenger Total Weight)
Maximum Pilot or Passenger Weight	90 kg
Maximum All Up Weight	390 kg
Maximum Landing Weight	390 kg
Minimum Pilot Weight (Solo)	70 kg
Fuel Capacity	35 Litres
Positive Load Factor (Limit)	+4G
Positive Load Factor (Ultimate)	+6G
Negative Load Factor (Flight)	0G
Negative Load Factor (Design Ultimate)	-3G

4.3 Performance

Stall Speed at Minimum Cockpit Load	29 mph
Stall Speed at Maximum Cockpit Load	30 mph
Height Loss	50 ft
Turning Flight Stall (30deg Bank)	34 mph
Height Loss	60 ft
Maneuvering Speed	60 mph
Cruise Speed (Trimmable)	50 - 70 mph
Maximum Level Flight Speed	85 mph
Never Exceed Speed	101 mph
Climb Rate At Maximum All Up Weight Speed	1000 ft/min 55mph
Minimum Sink Rate Speed	430 ft/min 45 mph
Take Off Distance to 15m Speed	140 m 55 mph
Landing Distance From 15m (Without brakes)	162 m

4.4 Engine and Propeller Limitations

Rotax 912 UL (See Engine Manual For Full Details and Latest Specifications)

Power Output 80 hp at 5800 rpm

Maximum rpm 5800

Maximum Continuous rpm 5500

Maximum CHT 150 degC (300 degF)

Maximum EGT 850 degC (1560 degF)

Oil Pressure Nominal Pressure 1.5 - 5 bar (22 - 73 psi)

Max. 7 bar (100psi)

Min. 1.5 bar (22psi) at 2800 rpm.

Oil Temperature most favourable temp 90 - 110 degC

Max 140 degC

Min 50 degC

Fuel Spec. MOGAS (4 Star or Unleaded) or AVGAS 100LL (See Engine Manual for Details)

Oil Spec. API Grade SF or SG Automotive Oil (Fully Synthetic Recommended)

Coolant. 80% Antifreeze Concentrate with additives against corrosion and 20% Water.

Gearbox Ratio 2.273:1

Propeller Options 3 Blade WD Ground Adjustable

58" Diameter 121Deg at 12" Pitch.

5.0 Normal Procedures

5.1 Transportation

Trike - We recommend that the trike unit be trailered to and from the flying field on a Mainair Roadrunner trailer. This means that the trike unit will be easy to load and safely transported. The trike unit may be transported either upright fully rigged, or folded down, although if traveling long distances upright is the preferred method. If transported upright ensure that the seat pins and front strut are fitted. If transported folded, then the transit 'Y' yoke supplied with the aircraft should be fitted into the lower front strut and the monopole securely tied to this. The long transit tie should be used to prevent the trike unit rolling side to side during transit, and should be fastened to one main axle leg, wrapped around the propeller transit insert (the small tube with the brightly coloured flag) and fastened to the other leg. The trike should be strapped firmly to the trailer with ties either passing through the wheels or over the axle legs.

Wing - Before transporting the wing make sure that it is packed properly in its bag, using the protective pads, failure to do so can result in small abrasion holes in the sail. The wing may be transported on a roof rack provided that some front support is provided for the wing overhang. A light weight aluminium ladder forms a convenient base to support the wing over its entire length. The Roadrunner trailer can also be supplied with wing racks to support the wing properly for transport. The wing should be secured using adjustable transit ties, available from Mainair.

5.2 Rigging

Wing

1. Select a clean, dry area and lay the wing down, with the nose pointing into wind, opening the zip to reveal the control frame and underside of the wing.
2. Open out the control frame and attach the corner joint, making sure that you do not trap any wires inside the control frame.
3. Lift the wing, and rotate it so that the wing is now lying on the ground with the assembled control frame flat on the ground underneath. Make sure that no wires are trapped beneath the frame.
4. Open out the wings, about one metre, and raise the king post on its pivot point and attach the top front rigging wire.
5. Open out the wing in stages, one wing at a time to prevent damage to the cross tubes.
6. Fit the top surface battens, starting with the tip battens and working in towards the root. Do not force the battens if they seem hard to push fully home. Do not hook the cord over yet.
7. Ensure that all wires are untangled and free from twist, particularly at the connections. Locate the cross tube tensioner cord and pull back as if to rig the wing, but do not attach the tangs, allowing the wing to relax in a fully-open position.
8. The battens can now be attached with the cords, by hooking one loop over then using the rigging tool to hook the second loop over.
9. Once the top surface battens are in place and tensioned the lower surface battens can be fitted. Make sure that these battens are in the pocket and have not been slipped in between the top and bottom surface by mistake.
10. When all the battens are in place and tensioned, the main cross tube tension can be pulled on with the cord inside the keel pocket. As the two wires are pulled back, locate the rear tang onto the location pin followed by the front tang. Allow the tension cord to retract slowly and fit the pins with the safety rings to prevent the tangs releasing.
11. Fit the nose batten, locking it behind the nut and the nose plate.
12. Raise the control frame by lifting the nose of the glider until the wing can be rocked back against the base bar, raising the control frame and allowing the nose wire catch to be fitted and pinned. This operation is helped by having a helper lift the keel at the rear at the same time as you lift the nose, both of you rocking the wing back over the control frame base bar. The nose cone should now be fitted.
13. Fit the washout rods, which are located inside the wing near the tips.

14. In light winds the nose can be lowered and the wing allowed to rest on the nose and control frame whilst the full pre-flight rigging check is carried out. In turbulence or strong winds it is best to have a helper hold the wings level at the nose whilst these checks are carried out.

Trike

1. Detach all transit ties from the trike unit and roll into position from the rear of the wing. Fix the main hang bolt and back up wire bolt, ensuring that the locking rings or pins are fitted through the bolts to prevent loss of the wing nuts. If the hang bolt is tight to fit check that the trike unit is straight behind the wing.
2. Put the trike propeller with one blade downwards and lift the nose of the wing until the keel tube rests on the propeller hub. Fit the front strut to the channel at the monopole top, and rest the strut over your shoulder. The two parts are best fastened together with the wizz pin in the wrong holes such that installation is easier. Lift the wing from the control frame base levering against the propeller hub until the folded seat of the trike unit can be locked down. This operation must be carried out with care and it helps to have a helper preventing the trike from rolling backwards, (wheel chocks are useful), your helper can also help by locking the seat frame.
3. Fit the front strut in place, with wizz pins, **the top pin must be pinned first**, and pin the telescopic seat struts with the 'R' clips, this may require rotating the inner tube slightly to aid alignment. Park the aircraft with the wing tip down, and into wind. Carry out a full pre-flight rigging check.
4. Fit the seat retaining straps onto the 1/2" tube, if these have been disconnected for any reason.

5.3 De-Rigging

De-rigging is the exact reverse of the rigging procedure. However it may be easier to remove the hang bolt and back up strap whilst the wing is resting with the keel on the propeller hub.

5.4 Rigging and De-rigging Inspection

As you rig your wing you should be meticulous in your inspection of each component. This is the best time to see potential faults which may be missed when the aircraft is fully rigged.

Never allow yourself to be distracted during assembly of your aircraft and always rig to a repeatable sequence. Do not rely on the pre-flight check to find faults, but look carefully at all aspect of your aircraft as you put it together. After flight, and particularly if you have had a heavy landing or suspect damage may have occurred through ground handling or cross wind landings, you must inspect the aircraft thoroughly. Wires should be checked for damage and fatigue, tubes for bends or dents and the sail for tears or abrasions. Please check the maintenance and repair section in this manual.

6.0 Pre-Flight Checks

Pre-Flight Check List - Mainair Blade

Wing

1. Apex Block
2. Hang Strap
3. Control Frame
4. Cable Ends
5. Lower Front Wire
6. Swan Nose Catch Secure
7. Nose Assembly
8. Nose Cone Secure
9. Stb. Inspection Panel
10. Stb Tip inc. Index Tip and Washout Rod
11. Trailing Edge and Batten Attachment
12. Rear Rigging Attachment
13. Keel and Pull Back Pins
14. Luff Lines
15. Port Tip inc. Index Tip and Washout Rod
16. Port Inspection Panel
17. Top Rigging and King Post
18. Trimmer Operation

Trike - With Wing Attached

1. Trike Connection - all rings fitted
2. Back-up Loop
3. Front Strut and Wiz Pins
4. Front Forks
5. Front Tyre
6. Foot Throttle and Hand Throttle
7. Brakes
8. Cockpit and Instruments (Check Battery If Fitted)
9. Main Keel
10. Seat Frame/Seat/Seat Belts
11. Seat Telescopes Pinned
12. Drag Links
13. Side Struts and Axles
14. Main Wheels and Spats
15. Fuel Tank Security - Front and Rear
16. Fuel Tap, correct tank selected
17. Fuel Line and Filters
18. Carburetor and Intake
19. Engine Mountings
20. Plugs/Plug Caps Secure
21. Electrical Wiring
22. Gear Box
23. Propeller and Bolts
24. Exhaust

7.0 Flight Characteristics and Operation Procedures

7.1 Operating Areas

Microlights are aircraft, and should be treated as such. Stay away from populated areas which will be restricted by buildings, trees, powerlines etc. Fly from airfields and open places, and if you have to consider whether a field is long enough to take-off from, it probably isn't. Take-off runs vary with trike model and conditions, the air density of the day, and the pilots skill and weight. Until you are totally familiar regarding the size of field needed, fly from recognized microlight airfields or huge open areas. Be ready for the engine to fail 50 ft up and make sure you have lots of room ahead to make a safe landing. Treat your field and the population around it with consideration. Having gained all your initial experience elsewhere at a recognized site, launch from your field and then fly away. The quickest way to annoy people living near a used field is to continually fly in and out subjecting them to what is in reality, a pretty aggravating noise, especially at week-ends. If they hear you once or twice during the whole day they are most unlikely to complain and you have a chance of keeping your field. Obey air law at all times and do not fly beyond your limits. Within the UK you must fly VFR at all times.

7.2 Load Distribution and C.G.

Maximum total all up weight must not be exceeded. Single or dual seat occupancy will affect the control bar position slightly. Maximum total cockpit load is 172kg, this is the combined weight of the two occupants. The maximum pilot or passenger weight is 90kg. However if one occupant is 90kg the other must weigh less than 82kg to remain within the maximum all up weight of the aircraft. **Failure to do so will invalidate the Permit to Fly.**

7.3 Single Seat Operation

Single seat operation should be carried out from the front seat only. Adjust the seat strap, by sliding it up or down the seat frame, until a comfortable backrest position is achieved. The more rearwards you sit will mean that the trike nose will be at a higher position in flight, particularly during climb out. Ensure that the rear seat buckle is firmly connected together to prevent it coming adrift and passing through the propeller.

7.4 Fuel Tanks and Fuel Priming

The aircraft is fitted as standard with a 22 litre tank beneath the engine, and has an option for an additional 13 litre tank beneath the passenger seat. The rear tank is left in position for rigging and de-rigging, but is quickly removable for cleaning and re-fueling after landing out. To remove the tank, detach the right hand engine strut at the ear bracket position with the quick release pin, and unscrew the fuel union at the fuel tap.

The under seat tank (long range tank) has to be removed during rigging and de-rigging. To install, the seat support straps are slipped off the retaining tube at the main seat channel, and the seat slide forwards. The tank is then positioned onto the trike keel. The tank strap then fits underneath the keel, around the monopole and is then pulled tight across the front of the tank so as to press the tank firmly onto the keel and into the bracket. Fit the hose connector and retaining elastic and prime fuel, checking for leaks. Ensure the fuel line is not kinked or trapped and position the breather tube in the clip on the side strut, and fit the fabric skirt over the filler neck. After fitting and checking, slip the seat loops back up between the channel and seat frame back and locate them on the retaining tube.

To prime the tanks, turn the fuel tank selector to the required tank and squeeze the primer bulb until you can feel it full of fuel, then select the other tank and repeat. The fuel tanks are now ready for in-flight fuel tank changes. However, when changing tanks it is always advisable to do so with an emergency landing field in sight, just in case you have not fastened the connections properly.

7.5 Flight Limitation Placards

The placard which details flight limitations is on the main keel tube immediately behind the front fork. This must not be obscured at any time. The throttle direction placard is mounted on the hand throttle housing. The fuel tank placards are mounted on the side strut adjacent to the fuel filler, and on the engine mount adjacent to the rear tank filler. The fireproof registration plate is fastened to the main seat channel, and the serial number on the side of the main seat channel. The trimmer control placard is located adjacent to the trimmer control on the wing upright.

7.6 Flight Control

The Mainair Blade is controlled by standard flex wing techniques, although the speed of response and lightness of action should be borne in mind for those pilots converting from other makes of wing.

Control Bar Movement	Aircraft Response
Bar pulled rearwards	Nose pitched down Aircraft speeds up
Bar pushed forwards	Nose pitch up Aircraft slows down
Bar pushed across to right	Aircraft rolls to the left
Bar pushed across to left	Aircraft rolls to the right

Conventional 3-axis pilots unused to flex wing control will find the control bar movement and resulting reactions confusing at first. They will have to positively think about all movements, particularly in stress situations. It is a legal requirement for 3 axis pilots to undertake a proper conversion course with a qualified instructor before being allowed to fly the Blade or any other flexwing.

7.7 Ground Handling

Flex wing microlights are unique in their ground handling ability. In wind over 5 mph, always turn the aircraft until one wing tip is resting on the ground, up wind, and apply the parking brake, which will help stabilize the aircraft until you are ready for flight. A ground picket or weight is very useful to tie the wing tip too in order to prevent damage to the tip and to hold the wing steady. When taxiing cross wind do not make the mistake of letting the up-wind wing go down as this will greatly increase the chances of the craft blowing over. Instead try to hold the wings dead level as this will present the minimum obstruction to the cross wind. When taxiing down wind, push the bar out to prevent the wind getting under the sail and putting you out of control. When taxiing on sloping ground be aware that the wing high above your head can affect the stability.

7.8 General Flying

Trike flying is pure flying. Never has there been such an easy to fly craft which is so efficient. Its simplicity can be deceptive, and just as you are sitting back enjoying yourself, things can go wrong. Frequent inspections and maintenance are the only path to enjoyable safe flying. Always fly within easy reach of landing fields, and beware of the temptation to show off in front of friends and spectators. Fly sensibly, for fun, and with care, and your Mainair Blade will give you many hours of pleasurable flying.

7.9 Take Off

Take offs are straight forward and the wing will lift the weight and hence fly when the correct air speed is reached. Make sure the trim control is set for take off, as indicated on the placard. The correct technique is to hold the wing parallel to the ground during the initial stages of the take off run so as to reduce the drag and increase the acceleration. At around 30 mph push the bar gently forwards slightly until the aircraft un-sticks, this should be approximately 35 - 40 mph. The trike unit will swing forward under the wing, and a wise pilot will hold the aircrafts climb rate down until a safe climb out speed is reached, 50 - 55 mph. Never, ever, push the bar full out holding it there as the aircraft claws its way skywards. Taking off and climbing in this manner is very inefficient, indicative of poor-piloting technique and very dangerous in the event of turbulence, wind gradient or engine failure.

Cross wind take offs can be conducted in winds upto 10 mph without additional piloting skills. Take off speeds should be increased slightly and the lift off made smartly countering any into wind tendency as the aircraft rotates.

During all aspects of flight the aircraft must be flown so that in the event of engine failure or loss of power, safe landing areas are always within reach. Providing the aircraft is being flown sensibly, an engine failure is not serious, and any competent and well trained pilot should be able to cope. Fully loaded the engine-off sink rate is around 400 - 450 feet per minute at 45 mph and increases rapidly as speed is increased.

7.10 Landing

The Blade copes well with cross-wind landings, but sensible pilots take great care to land exactly into wind wherever possible. Make your approach at about 50 - 55 mph and be aware of wind gradient during strong wind days. The flare is conventional, but the light pitch response can cause over correction and 'ballooning'. As soon as the wheels touch down pull back on the bar which will eliminate bounce and slow down the aircraft. The brakes are to be used primarily for power checks and emergencies. If a cross wind landing is unavoidable, make a conventional approach, flare, but do not allow the speed to decay excessively prior to touch down, and be ready for the twisting of the trike unit as soon as the rear wheel contact the ground. Whenever possible utilise whatever into wind distance you can - i.e. across the runway. Cross wind landings upto 10 mph should present no real problems, but exercise great care in stronger conditions, and because of the high torsional loads which can be imparted to the trike monopole and wing keel, always carry out detailed inspection after every cross-wind landing.

The rear drum brakes are intended as power check and taxing aids only. They should be operated with caution and not applied at speeds in excess of 15 mph other than in an emergency. Air-frame wear and tyre creep damage can occur from overuse of this lightweight system.

7.11 Engine Off Procedure

The Blade will glide quite safely with the engine off. Should the engine fail for whatever reason then a glide speed of 45 mph gives the best glide ratio of approximately 9/1. Ensure adequate obstacle clearance and aim to land 1/3 into your chosen field to prevent landing short. It is recommended to periodically practice emergency landings under controlled conditions with the engine at idle, occasionally clearing the plugs by increasing rpm to 4000 every 30 seconds. The engine can be restarted in flight without any special procedures or limitations, but ensure that re-starting, will not prove detrimental to the flying techniques required for an emergency landing.

7.12 General Flight Control

It is important that the wing is tuned to ensure equal wing section and therefore balance trim. A wing which exhibits a constant turn when flying 'hands off' will be tiring to fly and uncomfortable in turbulence, particularly when landing or taking-off. A properly tuned wing will fly completely 'hands off' throughout the whole range of power settings, although a slight tendency to turn owing to the torque reaction of the engine will always be present.

The roll control response will increase as the speed increases, and turns are very easy to co-ordinate. Prior to moving the bar sideways to roll speed may be increased by pulling back slightly. Once the aircraft has started to roll it should be pitched around the turn by moving the bar forwards. This action should be a smooth, fluid action. The bar movement completely relating to both speed and angle of turn. Steeper turn angles require more speed, more roll and more pitch. Shallow turns, less of all three. Great care must be taken to ensure both sufficient speed for the rate of turn required and to ensure that too much 'pitch' (bar forwards) is not applied or the wing will stall in the turn. Clean and coordinated roll control can be accomplished easily by thoughtful practice, and pays dividend in smooth and efficient flying.

7.13 Stalls

Fully loaded the stall occurs at approximately 30 mph and is clean and easily handled. Stalls within the flight envelope are perfectly safe to demonstrate providing you have sufficient altitude and the correct entry and exit techniques are used. To demonstrate the stall, the bar is slowly pushed away and the airspeed allowed to decay at about 1 mph per second. At around 42 mph the first signs of buffet will be felt through the control frame. As you continue to push the buffet will increase, and the bar force will increase and roll will feel progressively heavier and sluggish. The increased rearward bar pressure is caused by the wing trying to pitch up and recover, simply allow the bar to return to the neutral position and the aircraft will pitch down slightly and increase airspeed. If you continue to push the bar out, the back pressure will increase at around 30 mph (depending upon load) the wing will stall resulting in very high back pressure and immediate nose drop. Hold the bar out slightly until airspeed starts to increase and then return the bar to neutral position. Very smooth air conditions, clean piloting techniques and light cockpit loads may make the aircraft difficult to stall. It may stabilize in the incipient stall state and simply mush descending at a low airspeed but not actually stalling and pitching down. Simply recover as for an incipient stall.

7.14 Turning Stalls

Turning stalls from a 30 degree banked turn occur at 34 mph, prior to the stall, buffet will be felt through the base bar. Recovery from which is to move the base bar to just aft of the neutral position, and apply a slight corrective roll input and to then gently recover from the dive. With full power, no stall break can be achieved, although care should be exercised not to allow the nose to rise excessively.

7.15 Whipstalls

A whipstall is defined as a stall break induced from a pitch angle above 30 deg. At the stall break the wing will pitch down sharply and accelerate rapidly. The steeper the entry into this break, the steeper the subsequent dive and a high whipstall where airspeed decays significantly can lead to an irrecoverable situation. If the wing loses all airspeed at a high angle of attack, the nose drops sharply and it accelerates down and forwards. It can easily fly around the mass of the trike unit and occupants, completely inverting the aircraft. **WHIPSTALLS ARE EXTREMELY DANGEROUS.**

7.16 Flight in Rain and Ice

Microlighting is, in general, a fair weather sport but light rain has little effect on flying control. You will notice a slight increase in stall speed but the effects are minimal.

Ice, however, is more serious and can occur through icing meteorological conditions, or by flying a wing which is wet from the bag, without giving it time to dry out. Icing will affect handling and speeds markedly and at the first sign you should cease flying or fly below icing conditions.

In addition if the wing has been left out all night, and a frost has formed never fly until the wing is completely dry and all the frost on the wing has gone.

7.17 Minimum Cockpit Load and Operation At Light Weight

The minimum cockpit load is defined to ensure full flight control of the aircraft. Ballast can be added using a Mainair Boss Ballast bag, this is an approved container that straps into the rear seat, and is the only means by which ballast can be carried.

When operating solo, pilots should take care to operate the throttle sensibly. Excessively steep climb outs are unsafe since they lead to nose-high attitudes and engine failure in this situation may result in insufficient time/height to recover. During take off and climb out a reduced throttle setting is recommended when operating at low cockpit loads to keep within 30 deg pitch up limit. If full power is used then the climb speed should be increased to prevent an excessive nose up attitude.

7.18 Wing In-Flight Trimmer

The Blade is fitted with an in-flight trimmer, which allows you to trim the aircraft across a 15 to 20 mph speed range. The trim wheel is located on the right hand wing upright, and controls the amount of reflex on the wing, and hence the pitch attitude. For take-off the trim should be set to the take off position, by winding the trim lever clockwise, failure to do so will result in a long take off run combined with high pitch forces during the initial climb. Once airborne the trim can be adjusted to suit whatever speed is required. Similarly for landing the trim control should be set for the recommended approach speed of 55 mph.

7.19 Wing Tuning and Adjustment

All new aircraft are flown and set up either by Mainair Sports or Mainair Appointed Dealers. Prior to delivery to the customer a full check flight is carried out and adjustments made to the wing to ensure that it flies hands off at the right speed and is properly trimmed out. Owners are discouraged from making any adjustments and if you feel your Blade is not performing as it should, it is essential that it is returned to the factory or dealer for checking.

The following notes are for guidance only and since tuning of flex wings is a complicated and exacting science, no adjustment should be made without a full understanding of the principles involved.

7.20 Wing Trim

All Mainair wings are test flown before delivery to the customer, however, all flex-wings settle down after a few hours flying and the trim of the wing may change slightly. If the trim of a wing changes, either shown up as a change of speed, or for the wing to have a tendency to turn in one direction, check the following before jumping to any conclusions.

Make sure that the battens are in the correct side of the wing, that all battens with red plastic end caps are fitted to the port (left) side of the wing, and battens fitted with the green end caps to the starboard (right) side of the wing. During pre-delivery test flying, small adjustments may have been made to the shape of the individual battens and it is recommended that any changes from the standard shape is noted on the batten profile by drawing the actual shape of the batten on the profile. It is for this reason that it is imperative that battens are installed on the correct side of the wing. Check that the batten cord tension is the same for each side of the wing, and that they are to the same tightness as they were when the aircraft was new.

Any changes in the trim or handling characteristics of a wing due to settling down should be only very slight and occur gradually over a period of time. If a wing which has been flying correctly suddenly develops a turn or change in trim speed, it is most likely that some damage has occurred. It may be nothing more than the shape of the battens having been changed in transit, so first check the battens against the batten profile. If a wing is damaged, it should be returned to the factory or the nearest dealer for safety checks before it is flown again.

Having carried out the above checks, and if it is found necessary to adjust the wing proceed as follows:

7.21 Adjustments in Pitch

The wing is fitted with an in-flight trimmer which is used to alter the trim speed. However if the range of adjustment is such that you cannot fly your aircraft at the desired speed, then the hang point can be altered. Moving the hang point forwards increases the speed range by around 5 mph. If this adjustment has already been carried out and you cannot achieve the desired speed consult your dealer or the factory.

7.22 Adjustments in Roll

Check that the button pins on both index tips are set to the same, unless they have been adjusted previously. To correct a slight turn the tip battens, numbers 10, 11 and 12 will have to be altered in profile. If the turn is to the left then the left hand battens will have some reflex. This is carried out with the battens removed, and gently bending the trailing edge of the batten upwards, with the centre of bend approximately 4" from the end, such that the trailing edge is upto 1" higher when offered upto the batten profile. If increasing the reflex does not correct the turn sufficiently then the batten should be reprofiled and the left hand index tip lowered by one hole.

For wings with fully adjustable roll tips, identified by a nut in place of the button pin, fine tuning can be accomplished without the need to alter the batten profile. The tips are adjusted by slackening the nut on the trailing edge side of the index tip inside the sail, and twisting the wing tip to the new position, then tightening the nut again. The new position should be marked with a pencil so that it can be checked for slippage during pre-flight inspections. To correct a turn to the left the tips should be altered such that the trailing edge of the left wing is lowered first, by approximately 1/8" in the tip slot. If this is insufficient then the right hand tip should have the trailing edge raised, by approximately 1/8" in the tip slot. This process should be continued until the aircraft is flying straight. You will notice that with this method very fine tuning is possible to correct even the slightest hint of a turn. However ensure at all times that the tips are both adjusted to opposite sides of the normal position, and not both lowered or raised, and always mark the finished position with a pencil so that you can check for any signs of movement.

It is important that only one adjustment is made at a time, and that after each adjustment a check flight is made. All alterations should be recorded in the log book.

If after carrying out the above adjustments the aircraft is still not flying properly then the factory should be consulted, and the wing returned for checking.

7.23 Wheel Spats

The wheel spats must not be removed for flight, as they affect the overall handling of the aircraft in flight. The cut outs in the rear should ensure that they do not fill up with mud as is common with other wheel spats. If the aircraft is flown without the wheel spats in place the overall co-ordination of the trike and wing will be affected and the trike unit will swing beneath the wing more, making handling in turbulence and roll control less pleasant.

3.0 Starting Up

3.1 Starting Up

A trike is a lethal machine. A spinning propeller can be all but invisible and there have been countless accidents, don't think it cannot happen to you. Make sure that the trike brake is on or that the aircraft is against a chock, being aware that as soon as the engine starts there is propulsion and the trike will want to move. Clear all spectators away, particularly away from the area which would be affected by a fractured propeller. In practice, this means that everyone should be in front of the trike, but well clear at each side. Select a member of your crew to keep people away - as they tend to drift closer and you may be too busy to notice them. Check to make sure there is nothing that could be sucked into the propeller, such as seat belts, scarves, cleaning cloths, maps, clothing etc., etc.

Check that the throttle is fully closed, and the ignition is turned off. Turn the engine over to prevent the chance of a vapour lock in the oil system by turning the propeller over at least 6 times. Seat yourself and passenger in the seat, ensuring that the seat belt is secure. Select the required fuel tank and check that the throttle is closed, this is done by opening and closing the throttle and ensuring it returns as normal with no loose cables. Open the choke fully, check that the propeller area is clear. Switch on the two ignition switches and start the engine by turning the starter key. As soon as the engine starts check that the oil pressure rises to above 2 bar within 10 seconds, if oil pressure does not rise switch off the engine, and consult engine manual for details. Continue to run the engine at no more than 2500 rpm until the oil temperature reaches 50 degC (120 degF). Then check the ignition operation at 3850 rpm. The speed drop should be no more than 300 rpm. This check should be made before and after every flight.

The key switch has three positions, off, on and start. To start the engine follow the procedure as described above, if the engine has not started after 10 seconds, switch off and repeat. Do not pump the throttle when starting, as this increases the chances of flooding the engine. If it continues to fail to start then the engine may be flooded. After switching off the engine with the ignition switch always remember to switch off the starter key, and remove it. If the key is left in the on position then the battery may drain through any 12V systems connected to it. See wiring diagram for details.

9.0 Care and Maintenance

The essence of enjoyable flying is maintenance. Taking off and landing in fields and open spaces, which are often bumpy and rough subject the trike and glider to the most appalling loads, and it is essential that the aircraft is checked and maintained regularly to ensure that nothing has gone wrong. Vibration caused by the engine and propeller can fracture components, and vigilant inspection is required to spot any problems. Every flight should be preceded by a full pre-flight check and any noticeable failures or potential failures should be rectified before flight.

9.1 Airframe Life and Maintenance Schedule

The whole concept of flex wing flying revolves around the ability of the wing to distort and change shape to accommodate the flight loads and to be controllable in flight. The airframe is designed to be non-rigid, and designed strongly enough to be able to flex in this way for the lifetime of the airframe. However lifetime is very subjective and depends upon the use of the aircraft. Also it is safer to replace good components before a potential problem occurs which could prove catastrophic. Despite tests, experience and calculation, no-one quite knows how well the various components will stand up to the constant flexure, vibration and atmospheric corrosion the airframe is subjected to throughout its life. Constant cyclic loading causes fatigue, and fatigue shows itself as hairline cracks and fractures. Fatigue is greatly accelerated by vibration which can result from a slightly out of balance propeller, or by poor flying technique. The following schedule, excluding engine details, is a recommendation.

Maintenance Schedule - Please note that if the aircraft is used for training or operates in a harsh environment then the maintenance schedule should be amended accordingly. For example a training aircraft subjects the trike undercarriage to more cyclic loads, and hence will wear earlier than an aircraft that is flown regularly for flights lasting 3-4 hours each time.

A full visual inspection must be carried out each time you rig and de-rig. Additional full checks must be carried out at any time you suspect damage may have occurred i.e. heavy landings, transit damage etc.

Key: See separate paragraphs for specific details.

Inspection: Visually inspect, checking for loose fittings, hole elongation etc.

Major Inspection: Strip part and inspect all fittings and bolts. Replace bolts as required. Test for fatigue cracks at suspect areas. Do not re-use nyloc nuts more than twice.

Replace: Mandatory life of component. Wear or damage may dictate earlier replacement.

Hours: Means designated work should be carried out at each period.

The engine requirements have not been included below, but are included in the Engine Manual supplied with the aircraft and MUST be adhered to.

Every 10 Hours

Check batten profile shape.

Inspection : Wing keel, leading edges, cross tubes, control frame tubes, hang strap, all wing rigging wires, washout rod, wheels, front forks, throttle assembly, engine control cables, intake filter, fuel filter, propeller, exhaust, trike frame tubes, and all bolts. Remove and clean fuel tanks.

Grease front forks and rear suspension.

Clean fuel filter, carburetor bowls and air filter.

Every 50 Hours or Annually Whichever is the Sooner

Check propeller for balance and damage as necessary.

Every 100 Hours

Replace Hang Bolt, Cross Tube Leading Edge Pivot Bolt, Cross Tube Hinge Bolt.

Every 250 Hours or 3 Years Whichever is the Sooner

Major Inspection : Keel, Leading Edges, Cross Tubes, Control Frame Sides, Washout Rod, All Rigging Wires, Wheels and Bearings, Trike Airframe.

Every 250 Hours

Replace : Hang Strap, Lower Side Wires.

Every 500 Hours

Replace : Cross tube tension Wires, Monopole, Trike Keel.

Every 750 Hours

Replace : Wing Keel

Every 1000 Hours

Replace : Wing Leading Edges, Cross Tubes and Control Frame Tubes.

All other components replace as required.

It is a requirement in the UK for aircraft to be inspected and check flown annually by an independent BMAA inspector for renewal of the Permit to Fly. It is recommended that overseas aircraft, if no national requirements are in operation, are checked annually by an independent inspector.

We recommend that repairs or replacement of Primary and Secondary components is carried out at an approved microlight facility using only genuine parts.

Warning - The wing airframe is deceptively simple, but like all aircraft requires skilled and qualified attention. We do not recommend self repair or re-assembly by other than factory nominated repair agents. No replacement parts should be fitted unless they are factory supplied and identified since the whole wing structure is classified as primary structure.

9.2 Fabric

Care and maintenance starts the very moment you take delivery of your wing. 50% of all damage and degradation of your wing will take place when it is being stored or transported. Packing away properly is the most important single thing you can do to extend the life, efficiency and safety of this fragile piece of high technology. Dumping it in the bag with a few ties round it is the fastest way to rub holes in the sail, abrade rigging cable and dent tube. Despite the best care you can take, you will still have accidents with the odd wall or wire fence or your protection pads may slip and you will be faced with slight damage to the fabric. Where this takes place depends on how it can be repaired, high load areas such as a trailing edge being critical. Any cuts or tears through the trailing edge, sail fixing points or similar high load areas can only be repaired by Mainair Sports. Small damage to panels, leading edge cover etc. can be repaired with self adhesive tape which is cut to size, and pressed into place on the dry clean sail. We define small damage as abraded holes no more than 15mm dia and small cuts no longer than 20mm. Anything larger should be inspected by a qualified inspector.

9.3 Stitching Damage

All the seams are firstly joined with a double sided sail adhesive tape and then double zig zag sewn. thread damage never ever gets better and eventually runs. Since the wing is held together with stitches, it is pretty obvious what will happen when the stitching fails. If you abrade a seam, then have the damage repaired before it gets worse. Small non

loaded areas can often be repaired in situ by the tedious but effective method of hand sewing back through the original holes. Never use anything but matching polyester thread which is available from Mainair Sports.

9.4 Cleaning

The best answer to dirty sails is to keep them clean, but if all else fails and you need to wash your wing, then select a dry day and have access to a good hose and clean water supply. Never use strong soaps or detergents since soap residue can re-act with ultra violet light and degrade your fabric. We recommend a very mild liquid soap (washing up liquid) and a soft sponge. Gently wash the fully rigged wing, frequently hosing clean. Copious amounts of clean water will not harm the wing and can be very beneficial in removing sand and grit which may get trapped inside the leading edge pocket usually in the nose or wing tip areas. Ensure the wing is completely dry before de-rigging.

9.5 Ultraviolet Degradation

The sail is made from 100% Polyester fabric which, like all similar materials, is subject to degradation caused by exposure to sunlight. The fabric is treated with a special UV resister and in normal use the sunlight has little effect even over many years. Extreme conditions can have a disastrous effect. Leaving your aircraft rigged in, say, hot desert conditions for 6 months or so will result in complete breakdown of the fabric. Never leave your aircraft in sunlight for longer than is necessary, and check the condition of the mostly effected top surface against the protected undersurface at intervals.

9.6 Rigging Wires

The main danger with the rigging lies in kinking the wire, again caused by bad rigging and derigging. Once a wire has a kink, the strands are damaged and replacement is the only cure. The side wires are particularly important and should receive a frequent detailed inspection. Check for wire damage along the length but the main failure area lies immediately adjacent to the swaged fitting. Look carefully for signs of strand fracture at this position. Corrosion is a serious problem particularly in coastal areas and shows itself as a white powdery deposit. Corrosion cannot be cured and replacement is the only answer.

9.7 Battens

Battens form the wing shape and hence dictate the whole performance of the wing. They need treating with care, and since they are subject to constant tension both during flight and rigging, tend to lose their shape and flatten out. It is essential that they are reformed at frequent intervals and checked against the template. The best way to reform is to hold the batten against your knee and, whilst applying pressure to bow the batten, slide it side to side over the area you want to bend. Direct point bending will usually result in either a poor shape or a broken batten.

9.8 Tubes

The rules applied to the fabric also apply to the aluminium airframe. Care and consideration in rigging and derigging and transportation will pay huge dividends in airframe life. Any damage to one of the structural members is serious and can only be repaired by replacement. Tubes suffer from abrasion or indentation, the first accelerating fatigue fracture and the second reducing the strength of the part by a massive amount. If you bend, dent or damage the tubular members in any way, seek immediate professional advice before flying again and have replacement parts fitted.

9.9 Bolts and Nuts

Most of the airframe bolts are AN series bolts and only these type should be used for replacement. Any bolt which is bent or showing signs of corrosion should be immediately replaced. Nyloc nuts should only be used twice and wire locked nuts must be re-locked in place.

9.10 Fittings

Most fittings on the Blade are manufactured from aluminium alloy and then anodised. Damage can occur through scratching or by the stress of an unduly heavy landing or crash, or by general wear. Look for elongated holes and stress lines on the aluminium. Damaged items should be replaced.

9.11 Care and Cleaning

Microlights operate from fields, beaches, etc. and are subject to contamination from salt and water on beaches and mud and manure on fields. We recommend that your machine is cleaned thoroughly after every days use, particularly if used on the beach or near salt water conditions.

9.12 Salt Water or Beach Conditions

After each day it is essential that you hose off your machine completely with fresh water. Pay particular to areas where sand can lodge, such as between the axle plates and under small brackets and fittings. It is important to ensure that all tubes are plugged to prevent the ingress of salt water, but if you suspect that this may have happened, it is essential to remove these plugs and wash out any contamination. Salt water will corrode aluminium at an alarming rate.

9.13 Grass Field Operation

Mud and manure must be hosed off as soon as possible, since not only can it hide defects, but it can also contain corroding elements. A strong hose down with clean water is recommended, again paying particular attention to areas between plates and fittings.

9.14 Wheels

Wheels should be inflated to 22 psi. Over inflation gives a harder ride, but under inflation can lead to tyre creep and inner tube valve failure. Always check for tyre creep during pre-flight and post-flight inspections. If the wheel has been immersed in salt water it will be necessary to remove the wheel, and clean away all traces of the water to prevent corrosion.

Dust from the brake shoes must be cleaned out on a regular basis. The brake can be adjusted on the cable ends as required.

9.15 Control Cables

The control cables should be graphited occasionally, but removing all accumulated dust from them is essential. As they operate, they wear out and this dust will one day jam them unless they are kept clean. A frequent strip down to inspect the nipples and joints is good practice. Ensure that all cable runs are correct.

9.16 Exhaust System

You must pay particular attention to the exhaust system and its mountings. Frequently inspect for stress induced fractures and have these repaired as soon as they become evident. Carefully check the rubber mountings and replace any that show signs of fatigue. A cracking exhaust usually means an out of balance propeller.

9.17 Engine Mountings

Inspect all rubber engine mountings and the whole engine mounting assembly on a daily basis for signs of cracks and engine security.

9.18 Fuel Tanks, Fuel Lines and Filters

Ensure that the fuel tank is strapped tightly in place at all times, and inspect to ensure that no chaffing is taking place. Inspect and frequently clean out or replace the fuel line filters and in addition, wash out the air filters from time to time, a special cleaning agent is available for this. Remember to re-oil the intake filter after cleaning using K&N filter oil only. Ensure that all cable runs are straight and free from damage and carefully inspect the electrical ignition system.

9.19 Electrical System

Check for cable damage and for loose connections, and security of ignition switch. See drawing for wiring layout. Check that the battery terminals are tight, this is simply achieved by gently trying to turn the cable connection and checking that no movement occurs. The tightening torque should be 6Nm.

Get used to frequently going over the whole trike checking cables for stretch and elongation, aluminium plates and channels for worn holes and loose fitting bolts, and the general integrity of the trike structure itself. Also keep an eye on such obvious things as the seat and harness straps.

Remember, preventative maintenance is the only way to trouble-free and pleasurable trike flying. Please refer to maintenance schedules.

9.20 Propeller Care

All propellers need careful handling if they are to perform well for you. Avoid using your trike on dusty, stony ground, or anywhere where abrasive materials are sucked through the prop. The leading edges of the propeller can be protected with high-impact helicopter rotor tape. If this eventually shows signs of looseness, it should be replaced.

9.21 Mainair WD Ground Adjustable Propeller

The Mainair WD Ground Adjustable Propeller option offers an even greater reduction in vibration and a more trouble free life. Care and maintenance is reduced to checking the blade for any chips or damage, wiping dirt from the blade with a damp cloth, and if any vibration is present, to checking the blade pitch.

If the tips are to be painted to increase visibility, then a lacquer based, or enamel-based paint should be used, **NOT A CELLULOSE BASED PAINT**. Once the tips have been painted then the propeller should be checked for balance in the same way as a wooden propeller, however any out of balance can only be corrected by the further application, or removal, of paint.

The composite propeller should provide greater resistance to abrasion from dust, sand and rain, however the addition of propeller tape is still recommended to prevent chipping.

Blade Adjustment

Each blade is ground adjustable and is infinitely variable. It is held in the Aluminium hub with the 6 mounting bolts, and 4 clamping bolts.

Adjusting pitch is achieved by rotating the blade and checking the angle very carefully. Quarter of a degree will make a 100-200 rpm difference, so as you can see it is very critical. We have standardised on a position along the blade 12" from the hub centre and use the Mainair propeller setting jig and protractor to check the angle. The angle is critical for the behaviour of the propeller and to meet the noise requirements for the U.K.

Method for Pitch Setting

To adjust the propeller refer to the drawing on how to use the propeller setting tool. To adjust the blades all the propeller bolts need to be slackened off. Grasp the blade and flex it carefully backwards and forwards with one hand applying a twisting force near the hub with the other hand. Continually check with the setting jig and protractor. When satisfied all blades are correct, tighten up all bolts and re-check. Repeat as required. Remember, it is most important to set all 3 blades at exactly the same pitch angle. If the nyloc nuts lose their locking ability from repeated assembly and dis-assembly, they should be replaced.

All blades must be set at exactly the same pitch settings otherwise vibration will occur, resulting in a reduced aircraft life from fatigue. A small pen mark at the blade root can be used to determine if there has been any blade creep.

9.22 Propeller Pitch Settings

Engine type: Rotax 912 UL with 2.273/1 Gearbox

Propeller Options: Mainair WD Ground Adjustable 3 Blade
68" diameter 121deg at 12" pitch

DO NOT SET THE PROPELLER AT A DIFFERENT PITCH SETTING TO THE ABOVE LIMITS OR YOU WILL INVALIDATE YOUR PERMIT TO FLY AND NOISE TYPE CERTIFICATE.

Overseas Operations (Applicable to foreign registered aircraft only. Aircraft registered in UK must comply with pitch settings given above when operating overseas).

Varying climatic conditions or altitude operation may benefit from adjusting the propeller to a different setting from that above. The finer the pitch, the faster the engine will be able to turn the propeller and in general the more thrust will be developed. However, the noise level will increase and the fuel consumption increase. You must be careful to match the pitch to the engine RPM such that it is impossible to exceed the engine limiting speed as detailed in the manual even at VNE. Increasing pitch will tend to reduce thrust but will not necessarily improve fuel consumption. In addition, too much pitch may cause overheating and damage. If the engine speed is held down such that it cannot develop its full potential, the power produced will be low and the propeller will prevent the exhaust system functioning properly, leading to speed fluctuation.

SPARE PARTS ORDERING - Please order by giving full part description and trike or wing serial number.

Blade Adjustment

Each blade is ground adjustable and is infinitely variable. It is held in a nylon saddle and secured with 6 bolts which must be tightened evenly and checked from time to time. The bolts should be torqued to 14 ft/lbs.

To adjust the pitch slacken all 6 bolts on the blade to be adjusted which should be vertical. Grasp the blade and flex it carefully backwards and forwards with one hand applying a twisting force near the hub with the other. Continually check with the setting jig and protractor and when satisfied it is correct, tighten up all 6 bolts and recheck. Repeat as required. Remember, it is important to set the blades at exactly the same pitch angle. $\frac{1}{2}^\circ$ will make a 100-200 rpm difference, so you can see it is very critical.

The Mainair propeller setting jig and protractor is the tool which should be used, and we have standardised on a position 12" from the centre of the hub. If the nyloc nuts lose their locking ability from repeated assembly and disassembly they should be replaced.

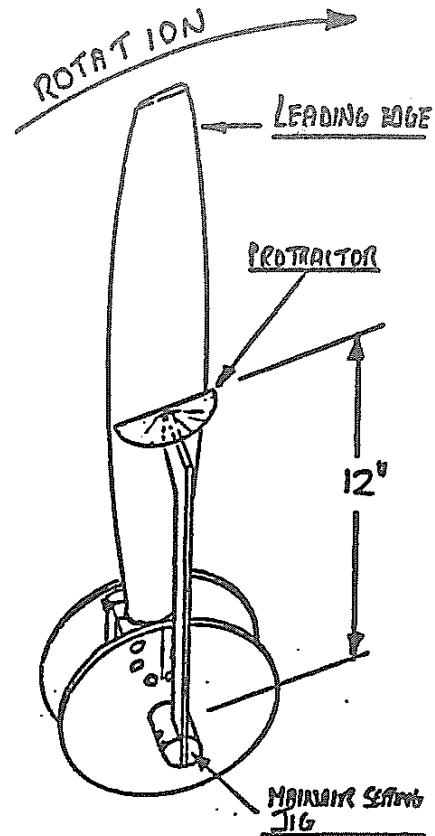

Propellor Balancing.

Multi blade propellers are best balanced on a suspension balancing tool. This accessory is available from Mainair Sports.

Rigging Aircraft.

The greater hub diameter necessitates a different rigging technique. Firstly set the propellor one blade down whilst lifting the nose of the wing and rolling the trike unit backwards. Before completing the lift, the wing keel should be moved over to one side rotating the propellor one blade vertical and alongside the fin. This allows the wing keel to drop down the side of the hub giving the necessary clearance between the control frame and cockpit nose. Take care whilst lifting not to damage the blade on the wing trailing edge during rigging and de-rigging. The wing keel must also be protected from damage by fitting a protection pad to the hub whilst rigging.

Wherever possible use a helper when rigging and always chock the rear wheels.

Hub Marking for pre-flight Inspection

It is a C.A.A. requirement that each blade be marked next to the hub so that any slippage can be easily identified. This is best achieved by marking between the split line of the retainer, using either a fine paint brush and paint or an indelible ink marker. Whenever the propeller is dis-assembled for overhaul; re-varnishing or blade replacement, any existing marks must be removed and the unit re-marked after final adjustment.

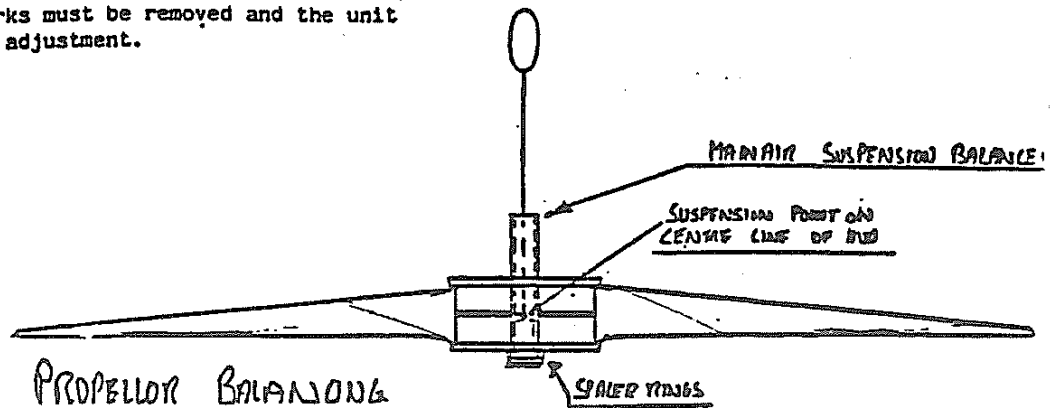
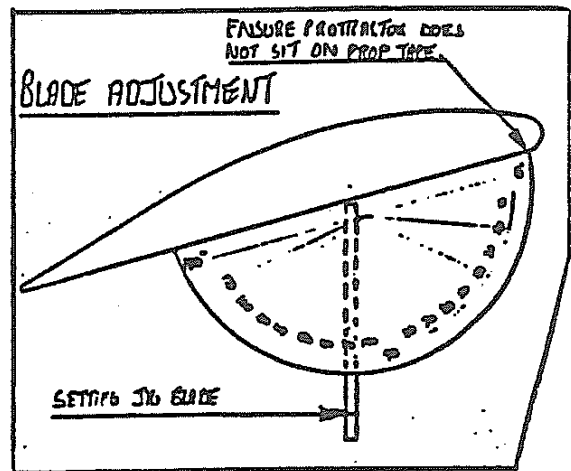

Accident/Incident Repair Log

Date	Damage Details	Repair Action	Signed

Annual Airworthiness Inspection

Date	Company	Comments	Signed

Owner List

Date	Name	Address

DWG NO. 99-44-57

TITLE Rotax 912 Wiring

DATE 8th Nov 1995

SUPERCEDES

DRAWN BY

CHECKED BY

REF DATE

AMENDMENT

MAINAIR SPORTS LTD.

TEL: 01706 55134

TOLERANCES UNLESS STATED OTHERWISE
GENERAL ± 10MM DIMETERS ± 0.05MM
CENTRES ± 0.5MM

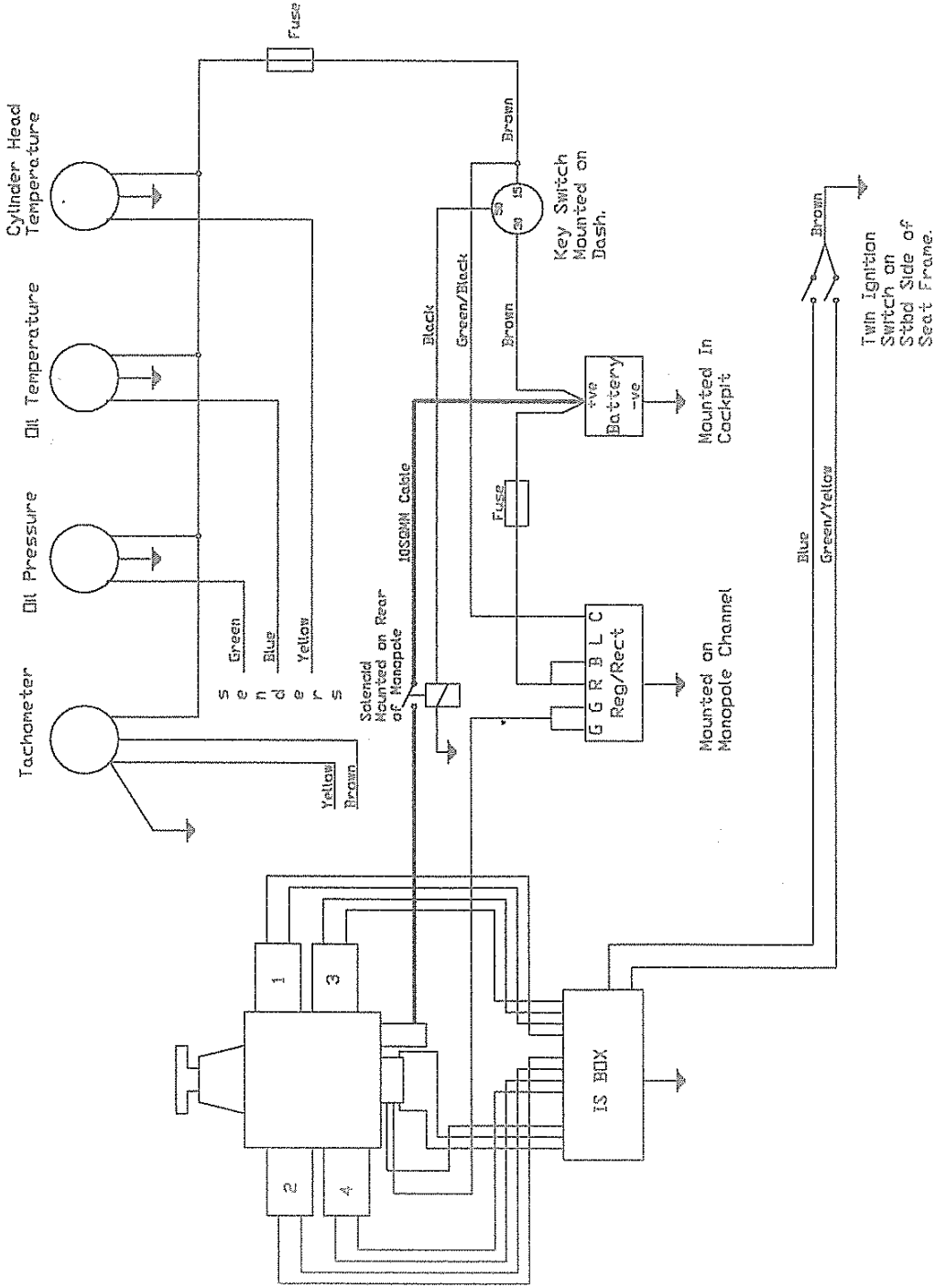

All Cables 0.75sqmm minimum

Note: For Rotax Flydat wiring details, see instrument manual.
+12 Volt supply for instrument use terminal IS on key switch.

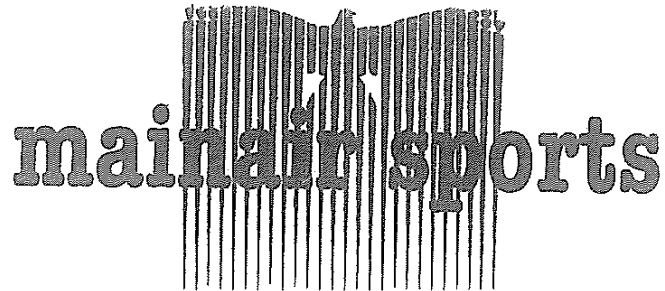

Mainair Modification 99 - 65 Litre Fuel Tank

Manual Addition

9th May 2002

This manual addition must be read in conjunction with the original aircraft manual.

Contents: Manual Addition
 Installation Instructions (issue 3)
 Parts List (issue 3)

Applicability: This Manual Addition covers the installation and operation of Mainair aircraft fitted with a 65 litre single fuel tank.

Aircraft Types: Gemini Flash
 Gemini Flash 2
 Gemini Flash 2 Alpha
 Mainair Mercury
 Mainair Blade
 Mainair Rapier
 Mainair Blade 912
 Mainair Blade 912S

Description

The 65 litre single fuel tank replaces the removable twin tank system that was originally approved with the Mainair two seat aircraft range. This single tank has the advantage of

increased capacity (cockpit load permitting) and no longer requiring to switch tanks in flight, or to remove a tank for rigging and de-rigging.

The tank is a rotational moulded Polyethylene material, with a nominal wall thickness of 5mm, and incorporates a sump with drain for removal of any water or other debris.

5.0 Normal Procedures

5.1 Transportation

Trike – With the single tank fitted it is preferred to transport the trike in the upright position with the cockpit fabric zips done up. This will help keep the fabric clean, and also prevent flapping and general wear.

5.2 Rigging & Derigging

Trike

The rigging and de-rigging process with the single tank requires the zips in the side of the cockpit fabric to be fully released prior to folding the trike down. Failure to do so will result in damage to either the cockpit fabric or the fibre-glass cockpit. Prior to flight these zips must be fastened all the way up, and the R clips used to lock the seat telescopes in position.

7.0 Flight Characteristics and Operation Procedure

7.2 Load Distribution and C.G.

With the 65 litre tank fitted it is acceptable to adjust the maximum fuel level with cockpit load to ensure that the placarded maximum take off weight is not exceeded. When the tank was first fitted to the aircraft, a placard detailing the cockpit load Vs fuel load was completed and fitted onto the aircraft, either on the cockpit dash or trike keel. These limits must be adhered to. The empty weight figure is valid for 5 years, after which the aircraft will require re-weighing and a new placard applying to the aircraft, as detailed in the Fitting Instructions. The fuel tank markings on the tank are approximately correct when the aircraft is parked on the ground, and are to be used as a guide in flight. **Note that the fuel level graduations over read in flight when there are more than 40 litres of fuel in the tank.**

7.4 Fuel Tanks and Fuel Priming

At the beginning of each days flying the fuel drain should be operated to check for any water in the tank. This should all be drained clear prior to flying. Ensure that the drain is secure once you have completed this operation.

7.5 Flight Limitation Placard

The placard which details cockpit load Vs fuel load is located on the cockpit dash or the trike keel, this must not be obscured, and must be visible to the pilot when seated in the cockpit.

9.0 Care and Maintenance

9.1 Airframe Life and Maintenance Schedule

Prior to each days flying the drain should be operated to remove any water or small debris that has collect in the tank. Large items of debris that do not fit into the drain can be simply siphoned out using a tube in the filler cap. The pick up pipe has a filter mesh so that these larger dirt items do not present an immediate hazard. All other maintenance requirements are as per the recommended schedule.